

Z1		Z2	
Pin	Function	Pin	Function
1	—	1	—
2	—	2	—
3	—	3	RS 0 A
4	POT ZAS	4	RS 0 B
5	POT GND	5	GND
6	POT SYG	6	+12V

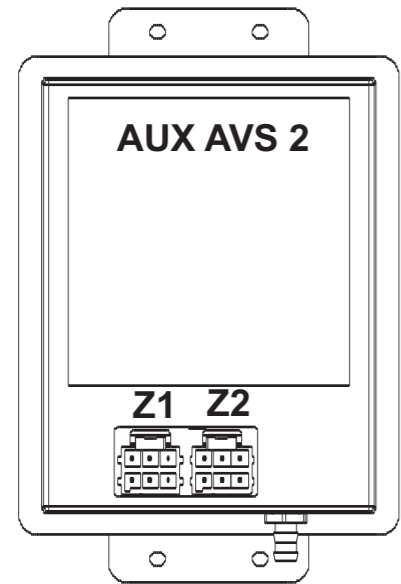

Instal inside the cabin.
Instal in the direction of flight
Connect to Pitot tube (total pressure)

Pin	Function
1	—
2	—
3	RS 0 A
4	RS 0 B
5	GND
6	+12V

EEM MOT 01 FL01.01

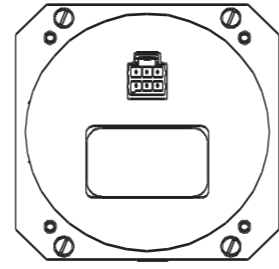

Pin	Function
1	—
2	—
3	RS 0 A
4	RS 0 B
5	GND
6	+12V

EEM MOT 01 FL02.01

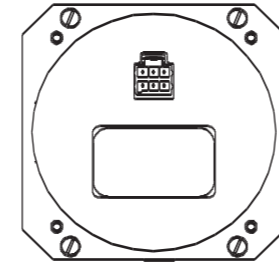

Pin	Function
1	—
2	RS 0 B
3	GND
4	—
5	—
6	—
7	RS 0 A
8	—
9	—

Diagnostic connector;
DB9 female
placed close to the instruments

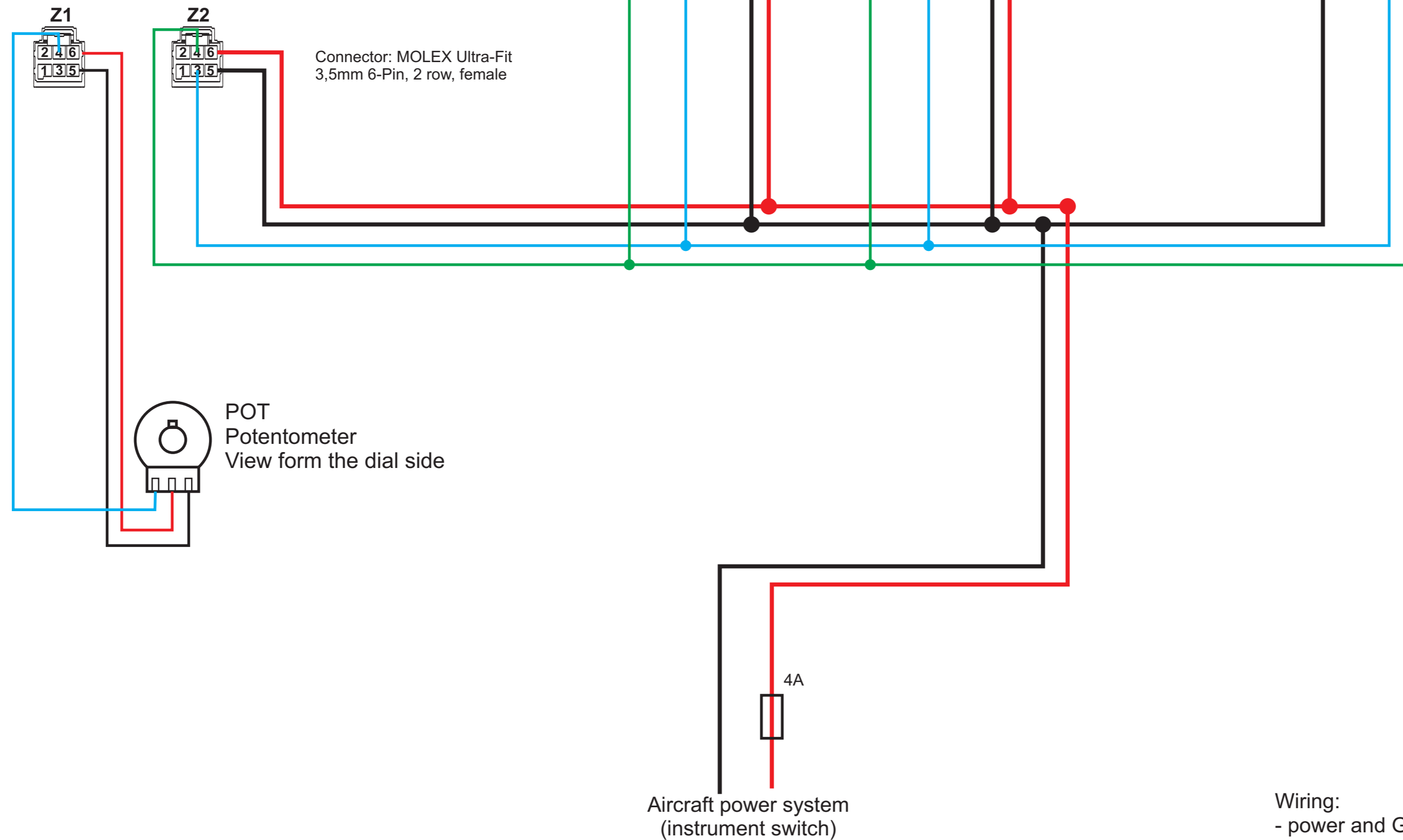
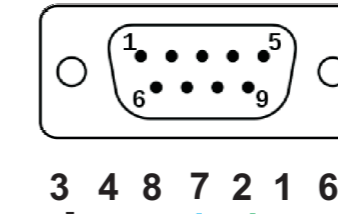

Connector: MOLEX Ultra-Fit
3,5mm 6-Pin, 2 row, female

POT
Potentiometer
View from the dial side

Aircraft power system
(instrument switch)

Wiring:
- power and GND: 0,75mm²
- Data bus: twisted pair 2x0,5 mm²

Title Flight Data System FLS AM1 01			Auto & Aero Technologies Sp. z o.o. Mazowiecka 10/5 20-723 Lublin POLAND	
Size: A2	Number: 2.05.34	Revision: 1.0		
Date: 2017-05-02	Sheet 1 of 1			
Drawing: Jacek Czarnigowski				