

Pin	Function
1	—
2	—
3	RS 1 A
4	RS 1 B
5	GND
6	+12V

EEM MOT 01 FE01.01

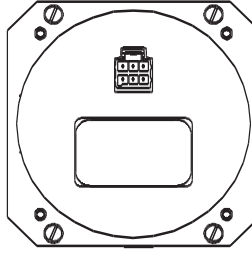

Pin	Function
1	—
2	—
3	RS 1 A
4	RS 1 B
5	GND
6	+12V

EEM MOT 01 FE02.01

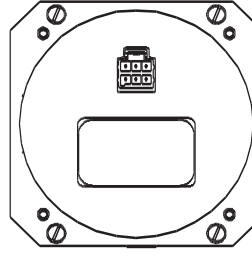

Pin	Function
1	—
2	—
3	RS 1 A
4	RS 1 B
5	GND
6	+12V

EEM MOT 01 FE03.01

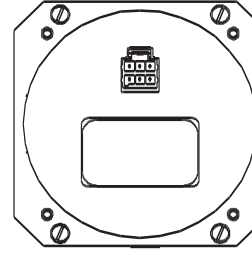

Pin	Function
1	RS 2 B
2	—
3	GND
4	RS 1 B
5	—
6	RS 2 A
7	—
8	RS 1 A
9	—

Diagnostic connector;  
DB9 female  
placed close to the instruments

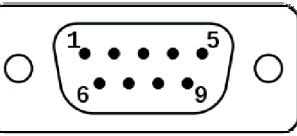

Connector: MOLEX Ultra-Fit  
3,5mm 6-Pin, 2 row, female

Aircraft power system  
(instrument switch)

Pin	Function
1	GND
2	MAT
3	+ 5V
4	MAP

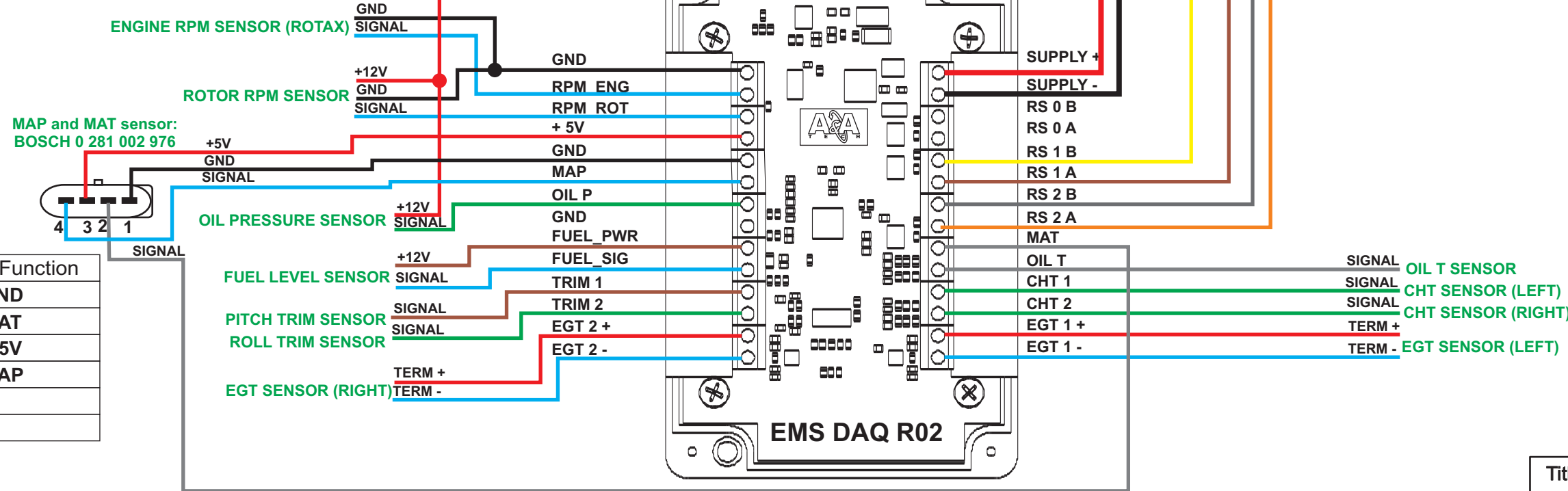

Put close to the engine.

Wiring:  
- power and GND: 0,75mm<sup>2</sup>  
- Data bus: twisted pair 2x0,5 mm<sup>2</sup>

Title Engine Data System EDS AM1 GR01			Auto & Aero Technologies Sp. z o.o. Mazowiecka 10/5 20-723 Lublin POLAND	
Size: A2	Number: 2.05.36	Revision: 1.0		
Date: 2017-05-02	Sheet 1 of 1			
Drawing: Jacek Czarnigowski				